

Smart Assistive Navigation Device for Visually Impaired People

Rohit Mohite ,Ashish Gosavi, Gaurav Gosavi, Krishnaprasad Menon

Department of Electronics Engineering
Vidyalankar Institute of Technology, Mumbai

Prof. Nayana Mahajan

Vidyalankar Institute of Technology, Mumbai

ABSTRACT:

This paper is based on the design of a smart assistive device to help visually impaired people. Visually impaired people have been facing a lot of hardship in their day-to-day life. Navigating from one place to another is a hard task for them and the conventional blind walking stick has its own drawbacks or limitations. It is not of much assistance to these people of our society. Our research is motivated by the inability of the physically disabled people in their ambulation, and we took an attempt to make their routine life painless and trouble-free. We designed a device which can be of immense utility to the sightless people. We designed a smart glasses and application by integrating various sensors with Arduino uno. The paper presents the functionalities and the working principle of the smart glasses and application. The varieties of tasks they are capable of accomplishing. The novelty of our work lies in processing data from both and provide a better solution for navigating and day to day activities.

Keywords: Ultrasonic sensor, camera, esp 32 microcontroller, imager to text

I. INTRODUCTION:

People suffering from visual impairment have decreased the ability of visual perception. Visual impairment can include a person who has lost his ability to see completely, or it can also include a person who is suffering from a partial loss of vision. According to the World Health Organization, there were around 285 million visually impaired people in the world. Among them 285 million people, 39 million people are completely blind, and 245 million people have low vision. The limited vision of the sightless people put them in various challenges. Visually impaired people face difficulties while reading, studying navigating from one place to another and countless others. People suffering from night blindness cannot read in absence of light. Blind people need some assisting device to help them interact with the environment. For ages, they have used sticks to help them locate obstacles in their way. This was not an efficient way of commuting. Less than 1 percent of the books available in the market are in braille's script causing lack of learning resources for the visually impaired peoples. Many technologies have been evolved.

around visual impaired people like the depth sensing and sonification. Research has going on GPS enabled guide for blind people, usage of sensors like ultrasonic sensor which used to store our data.

In this research paper, we have discussed a device which is designed to help the visually impaired people. We have developed a smart pair of

glasses and cap which has multiple uses. Over the past few years, noticeable improvements in the image processing techniques have immensely ameliorated the visually impaired. Involvement of computer vision along with other sensors has been essential in many devices. Our multifunctional smart glass is integrated with camera and a microcontroller. The optical sensor (camera) senses the surrounding and feeds data into the microcontroller for processing. The microcontroller manages and processes the raw data and provides the user with the desired information. Impaired people cannot localize objects. Our proposed smart glass can detect and classify objects. It detects the name or label of an object and provides the user with audio output through the earphones. It can read the text and render the user with audio output of the same.

There are two main processes in the system: the calibration process, and the detection process. The calibration process is done when the user uses the device for the first time. This process asks the user to move their head up and down slowly in a swinging-like motion (with the device on it). All the angles from 0 degrees to 45 degrees are collected with their corresponding distances. These input angles and distances are stored for further use with the ground level detection mode.

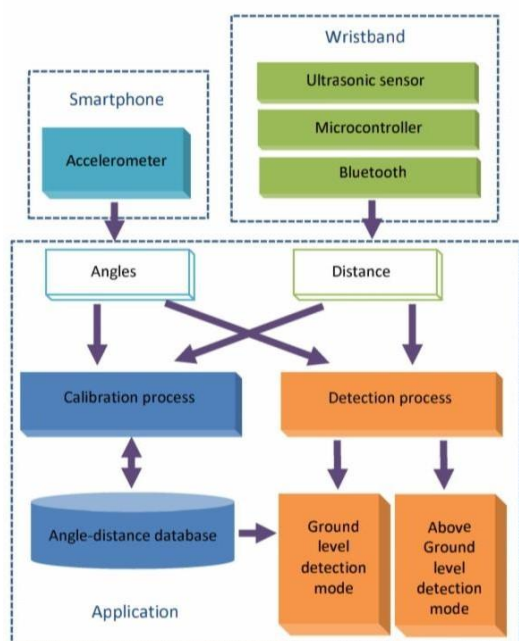

Figure.1 flow diagram

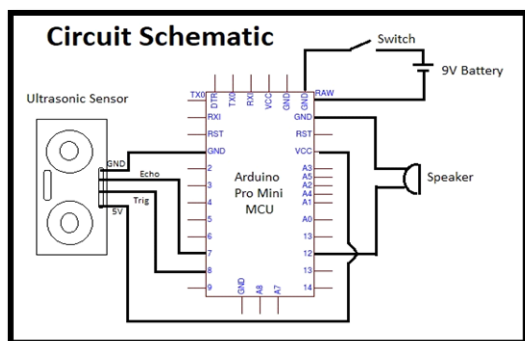

Figure.2 Circuit schematic

Fig1. illustrates the overview of the application processes. The detection process consists of two working modes, the above ground level detection mode, and the ground level detection mode. The first mode is activated when the user points their arm with the angle between the arm and the torso (vertical axis) more than 45 degrees. This mode uses the acquired distance information solely to detect higher obstacles. If an obstacle is within the detection range, the device warns the user with audio feedback (depending on the user settings). This mode can only detect obstacles and high bumps and it cannot be used to detect holes on the ground. So that, the second mode is activated when the user is pointing their head downward with the angle less than 45 degrees. In this mode, the stored distances in the database are used in comparison with the acquired distance at the same angle. If the acquired distance is shorter than the stored distance plus a constant, the device warns the user that a raised obstacle a bump on a road is detected.

Software Development Kit for development. The application was based on navigation system which used TTS(Text-to-Speech) for visually impaired people to provide a navigation service through voice command. Also, Google Map API was used to apply map information. Smart Phone recognized the voices, search for destination, routes, and provide the route to the user through voice command. The primary function was to search destination through voice recognition and Google TTS (Text-to- Speech) service.

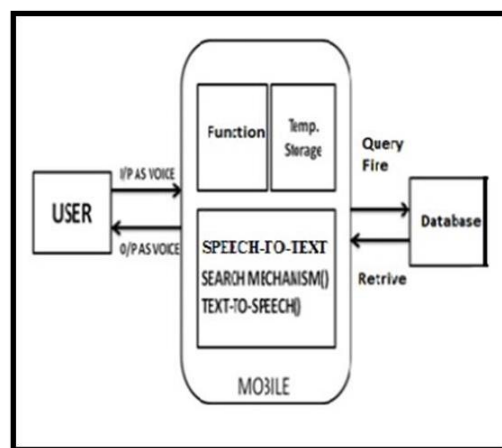

Figure.3 Software development kit

Hardware

1. ESP 32microcontroller:

The predecessor of ESP32, the ESP32 has a built-in processor. However due to multitasking involved in updating the Wi-Fi stack, most of the applications use a separate micro-controller for data their processing, interfacing sensors and digital Input Output. With the ESP32 you may not want to use an additional micro- controller. ESP32 has Xtensa® Dual-Core 32-bit LX6 microprocessors, which runs up to 601 DMIPS. The ESP32 will run on breakout boards and modules from 160Mhz upto 240MHz. That is very good speed for anything that requires a microcontroller with connectivity option.

The two cores are named Protocol CPU (PRO_CPU) and Application CPU (APP_CPU). That basically means the PRO_CPU processor handles the Wi-Fi, Bluetooth and other internal peripherals like SPI, I2C, ADC etc. The APP_CPU is left out for the application code. This differentiation is done in the Espressif Internet Development Framework (ESP-IDF). ESP-IDF is the official software development framework for the chip.

Arduino and other implementations for the development will be based on ESP-IDF.

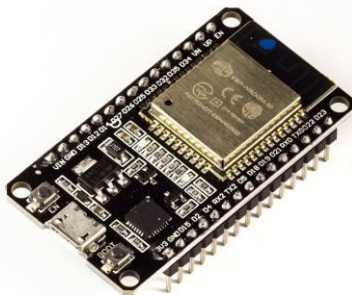

Figure 4: ESP 32 microcontroller

Technical specifications:

- The ESP32 is dual core, this means it has 2 processors.
- It has Wi-Fi and Bluetooth built-in.
- It runs 32-bit programs.
- The clock frequency can go up to 240MHz and it has a 512 kB RAM.
- That board has 30 or 36 pins, 15 in each row.
- It also has wide variety of peripherals available, like capacitive touch, ADCs, DACs, UART, SPI, I2C and much more.
- It comes with built-in hall effect sensor and built-in temperature sensor.

2. Ultrasonic Sensor

An ultrasonic sensor is an instrument that measures the distance to an object using ultrasonic sound waves.

An ultrasonic sensor uses a transducer to send and receive ultrasonic pulses that relay back information about an object's proximity.

High-frequency sound waves reflect from boundaries to produce distinct echo pattern.



Figure 5: Ultrasonic sensor

Wire Connecting direct as following:

- 5V Supply
- Trigger pulse Input
- Echo Pulse Output
- 0v Ground

A. How Ultrasonic Sensors Work.:

Ultrasonic sensors work by sending out a sound wave at a frequency above the range of human hearing. The transducer of the sensor acts as a microphone to receive and send the ultrasonic sound. Our ultrasonic sensors, like many others, use a single transducer to send a pulse and to receive the echo. The sensor determines the distance to a target by measuring time lapses between the sending and receiving of the ultrasonic pulses.

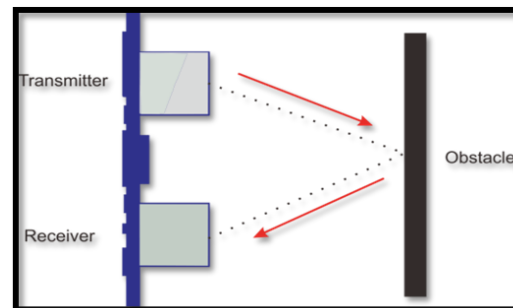

Figure 6: Ultrasonic sensor working.

Why to use an ultrasonic sensor:

Ultrasound is reliable in any lighting environment and can be used inside or outside. Ultrasonic sensors can handle collision avoidance for a robot, and being moved often, if it isn't too fast.

Ultrasonics are so widely used, they can be reliably implemented in sensing applications, water level sensing, drone applications and sensing cars at your local drive-thru restaurant or bank.

1) Ultrasonic Sensors are best used in the non-contact detection of:

- Presence
- Level
- Position
- Distance

Non-contact sensors are also referred to as proximity sensors.

2) Ultrasonics are Independent of:

- Light
- Smoke
- Dust
- Color
- Material (except for soft surfaces, i.e. wool, because the surface absorbs the ultrasonic sound wave and doesn't reflect sound.

Software:

1. Micropython:

Micro Python is a tiny open source Python programming language interpreter that runs on small,

embedded development boards. With Micro Python language you can write clean and simple Python code to control hardware instead of having to use complex low-level languages like C or C++ or java which are pretty much used by Arduino boards.

The simplicity of the Python programming language makes Micro Python an excellent choice for beginners who are new to programming and hardware. However Micro Python is also quite full-featured and supports most of Python's syntax so even seasoned Python veterans will find Micro Python familiar and fun to use.

Beyond its ease-of-use Micro Python has some unique features that set it apart from other embedded systems: This allows you to connect to a board and have it execute a code without any need for compiling or uploading perfect for quickly learning and experimenting with hardware.

Like the normal Python programming language Micro Python is 'batteries included' and has libraries built in to support many tasks. For example, parsing JSON data from a web service, searching text with a regular expression, or even doing network socket programming is easy with built-in libraries for Micro Python. For advanced users Micro Python is extensible with low-level C and C++ functions so you can mix expressive high-level Micro Python code with faster low-level code when you need it.

II. RESULT AND ANALYSIS:

The overall idea about the project we get from the (Figure[1].flow diagram).All the electronics components arrangement is shown in the (Figure[2].circuit schematic).The application we made for this project is based on text to speech which is going to provide the navigation, you can see this in (Figure[3].Software development kit).The main brain of our project is esp 32 microcontroller which is shown in (Figure[4].esp 32 microcontroller).The sensor we used in this project for distance measuring and object detection is ultrasonic sensor which is shown in (Figure[5].ultrasonic sensor).The ultrasonic sensor sends and receives the ultrasonic rays which is shown in(Figure[6].working of ultrasonic sensor).After collecting the data from the sensors then comes the data processing part which is done in two steps image-to-text and text-to-audio, the actual flowchart of this is shown in(Figure[7].programming flowchart).The text-to-

audio output we get is shown in (Figure[9].text to speech output).The object detection through camera is done in matlab whose output is shown in (Figure[10].camera simulation in matlab).The actual hardware assembly for our project is shown in (Figure[11].esp 32 programming).

Flowchart:

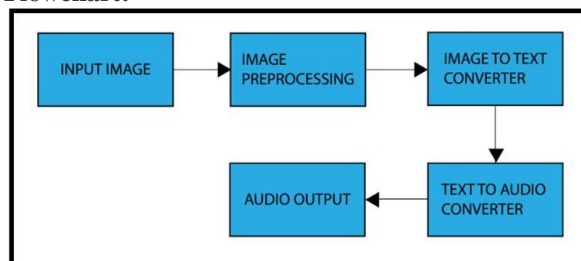

Figure 7: programming flowchart

Final outputs:



Figure 8: image to text output

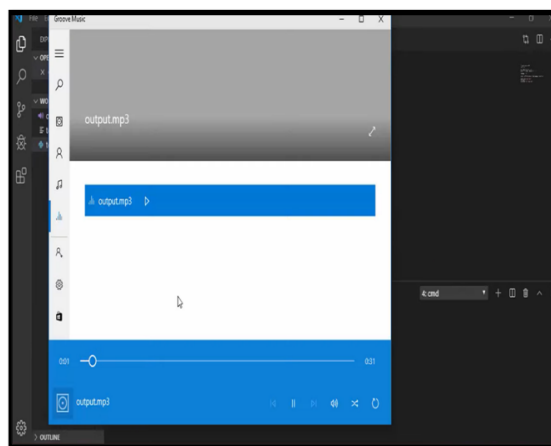

Figure 9: Text to audio output

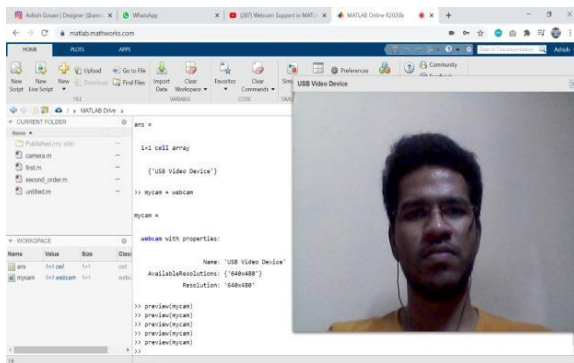

Figure 10: Camera simulation matlab

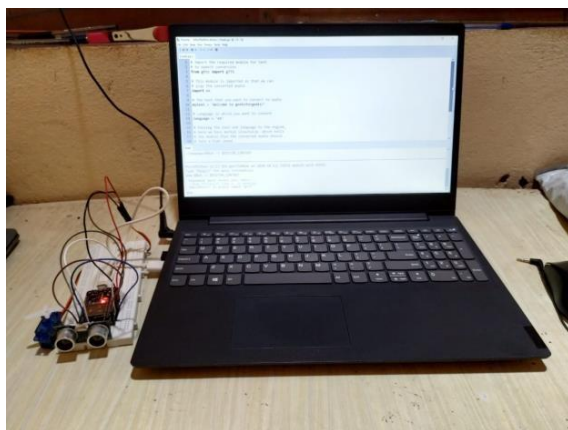

Figure.11 esp 32 programming

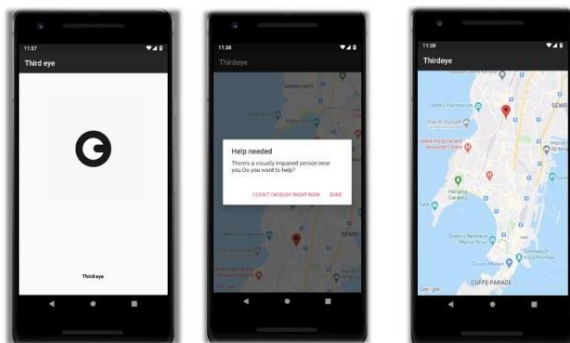

Figure 12: Third eye app

III. CONCLUSION:

Visually impaired people face a lot of problems when they go to an unknown area or while commuting from one place to another place. So, we have created navigation devices which would make visually impaired people more independent in their day-to-day task and to commute particularly visually impaired person wants to know what is that particular object that can't be sensed, what is the distance from the user to the obstacle and also what is relevant info available in that object so our technology deals with that and gives the exact info to the users.

In this research paper, we have presented a wearable technology in the form of smart Glasses which help blind person as well as visually impaired

people in their daily routine. This wearable cost friendly technology definitely helps blind people in their day to day life.

REFERENCES:

- [1]. "Vision Impairment and Blindness", Online: <https://www.who.int/news-room/fact-sheets/detail/blindness-and-visual-impairment>, [this accessed 2 October 2019].
- [2]. "Visioneers.Org-Our Organization", <https://visioneers.org/our-organization>, [accessed 2 October 2019].
- [3]. "Visioneers.Org - We Teach Blind People to See with Sonar Vision", <https://visioneers.org>, [accessed 2 October 2019].
- [4]. "Are bone conduction headphones good enough yet? - Theverge.", Online: <https://www.theverge.com/2016/10/24/13383616/boneconduction-headphones-best-pair-aftershokz>. [Accessed: 02-Oct-2019].
- [5]. L. Thaler, R. De Vos, D. Kish, M. Antoniou, C. Baker, and M. Hornikx, "Human echolocators adjust loudness and number of clicks for detection of reflectors at various azimuth angles," Proc. R. Soc. B Biol. Sci., Vol. 285, pp. 20172735, 2018.
- [6]. Norman, L. J., and L. Thaler." Human echolocation for target detection is more accurate with emissions containing higher spectral frequencies, and this is explained by echo intensity." Perception, Vol. 9, No. 3, 2018.
- [7]. B. Schenkman and V. K. Gidla, "Human echolocation in different situations and rooms: Threshold values," presented at the 173rd Meeting of Acoustical Society of America and 8th Forum Acusticum, Boston, Massachusetts, pp. 015002, 2017.
- [8]. A. G. Hagargund, S. V. Thota, M. Bera, and E. Fatima, "Image to Speech Conversion for Visually Impaired," Vol. 03, No. 06, pp. 7, 2017.
- [9]. H. Jabnoun, F. Benzarti, and H. Amiri, "Object detection and identification for blind people in video scene," In 15th International Conference on Intelligent Systems Design and Applications (ISDA), Marrakech, pp. 363-367, 2015.
- [10]. Rfid based indoor navigation with obstacle detection based on a* algorithm for the visually impaired. International Journal of Information and Electronics Engineering, 5(6):428, 2015. Jayron Sanchez, Analyon Yumang, and Felicito Caluyo

- [11]. Sensor-Based Assistive Devices for Visually-Impaired People: Current Status, Challenges, and Future Directions, by Wafa Elmannai and Khaled Elleithy.
- [12]. Syed Tehzeeb Alam, Sonal Shrivastava —Smart Device for Blind People| Journal: International Journal of Engineering Research & Technology (IJERT), ISSN: 2278- 0181, Vol. 4 Issue 03, March-2015.
- [13]. Crosswalk and traffic light(2013)frontier of computer vision workshop. J.Choi.